

J. L. NORTON.  
Loom.

No. 163 799.

Patented May 25, 1875.

Fig. 1.

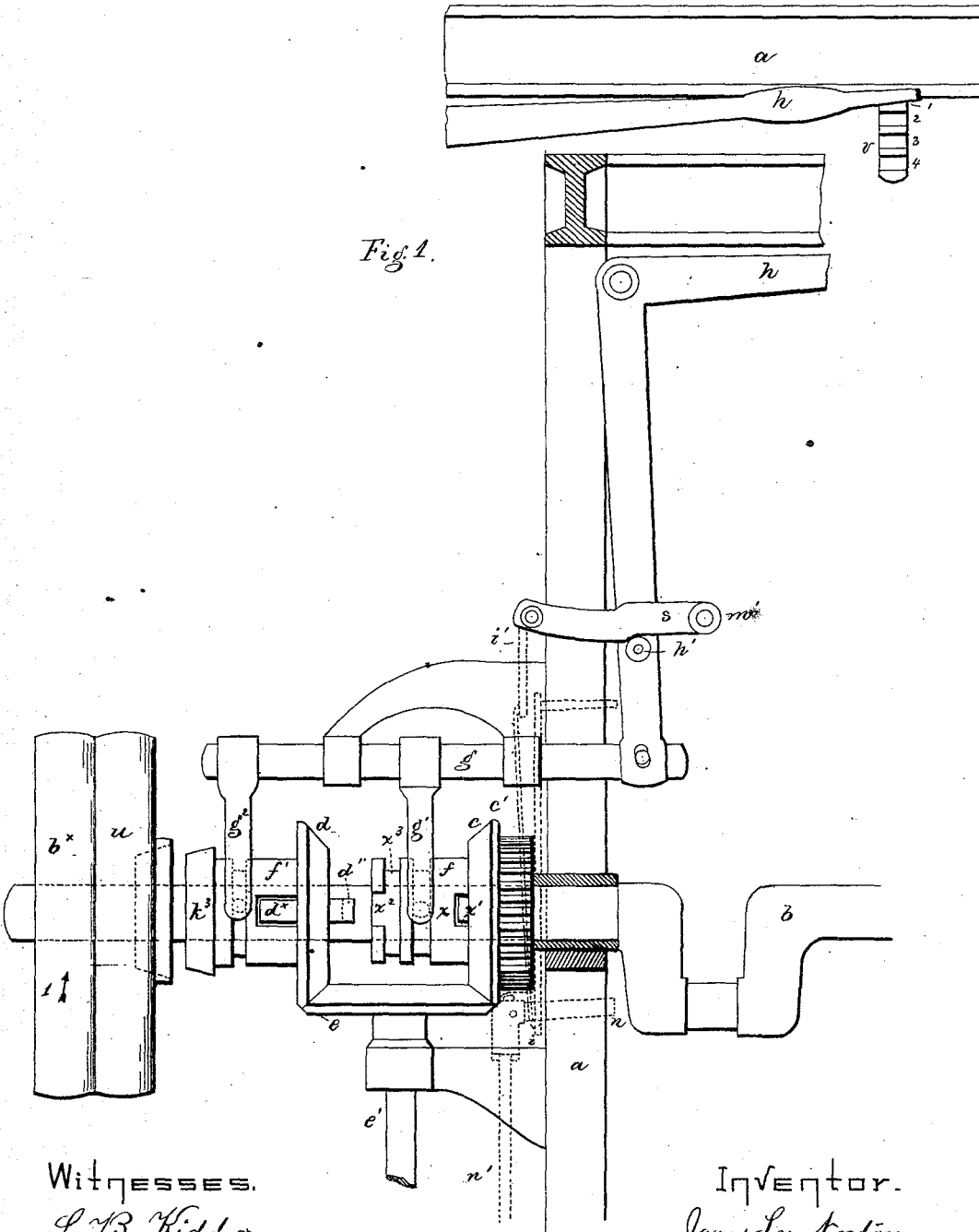

WITNESSES.

S. B. Kidder  
Wm. Pratt.

INVENTOR.

James Lee Norton

PER Crosby & Gregory Attys.

J. L. NORTON.  
Loom.

No. 163,799.

Patented May 25, 1875.

Fig. 2.

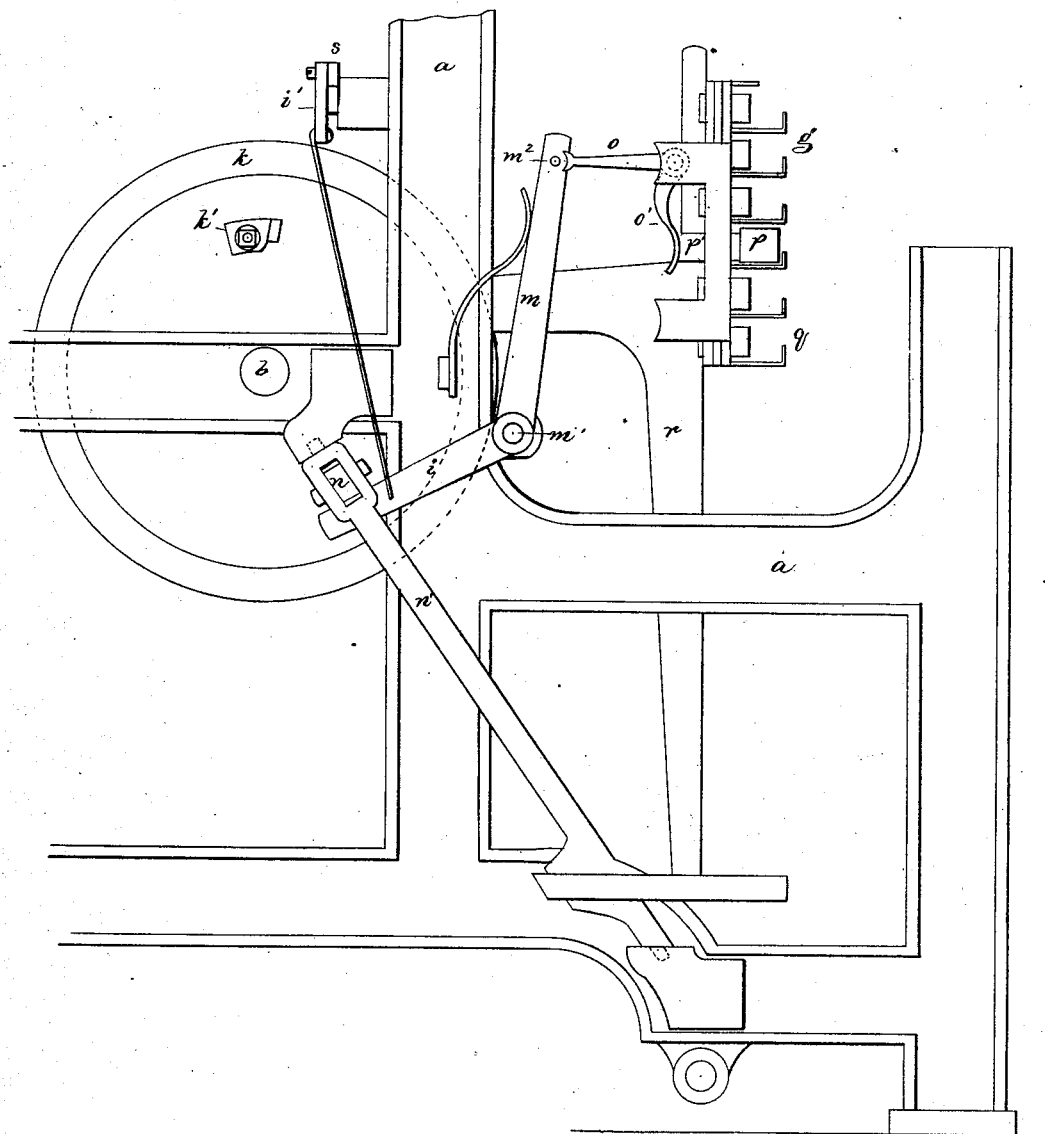

Witnesses.

*S. B. Kidder*  
*Wm Pratt*

Inventor.

*James Lee Norton*

PER *Crosby & Gregory* Attys.

# UNITED STATES PATENT OFFICE.

JAMES LEE NORTON, OF LONDON, ASSIGNOR TO GERALD HOPPER, OF DENMARK ROAD, CAMBERWELL, ENGLAND.

## IMPROVEMENT IN LOOMS.

Specification forming part of Letters Patent No. 163,799, dated May 25, 1875; application filed March 23, 1875.

### *To all whom it may concern:*

Be it known that I, JAMES LEE NORTON, of Belle Sauvage Yard, in the city of London, England, have invented an Improvement in Looms, of which the following is a specification:

This invention relates to a method of reversing the motions of a loom, or causing a cessation of movement in one part of a loom while the other part turns backward or forward, as may be required. On the crank-shaft of the loom, or otherwise, two bevel-wheels are mounted loosely, each gearing into a third bevel-wheel, and a catch-box slides on a shaft between the wheels, in the ordinary way of reversing-gear well known. On the same shaft, between one of the bevel-wheels and the loose strap-pulley, a cone is mounted and connected by projections to the bevel-wheel, but it is free to slide laterally on the shaft a certain distance without being disconnected from the wheel. A beveled rim is attached to the loose pulley, which holds the cone by friction, so that both revolve together when in contact. The said cone is connected to the catch-box, and both are moved simultaneously in a lateral direction on their shaft. They are also connected to a rod or hand-lever, or otherwise placed in a convenient position to be operated on by the weaver. The hand-lever is also connected to the picking part of the loom, to throw it in or out of action. The reversing-gear drives the shuttle-box and shedding motions. In working a loom it often happens some mistake has to be rectified. In such cases the weaver pulls the hand-lever to a certain position, which disconnects the picking, and the loom, with all its other parts, can continue at work as long as necessary; or, when it is necessary for these motions to return back to repeat the pattern backward to a true shed, the hand-lever is pulled a little farther, which causes the catch-box to take hold of the other bevel-wheel. This causes the shuttle-box and shedding motions to run backward as far as desired, while the crank and batten run forward, as usual. If, while the shuttle and shedding motions run backward, the batten is required to be stationary, the weaver can

pull the hand-lever a little farther, and the cone is pressed in frictional contact with the side or cone-seat of an adjacent pulley, and the catch-box disconnected from the bevel-wheels, thus allowing the aforesaid pulley to actuate the shedding and shuttle-box motions in a reverse direction, while the crank-shaft and batten of the loom remain at rest.

The above plan is applicable to fancy-loom generally.

In the drawing, Figure 1 shows, in elevation, so much of a loom as is necessary to show how my reversing mechanism operates; and Fig. 2, an end view of the loom, but with the reversing mechanism omitted.

The frame of the loom is designated by *a a*. *b* is the crank-shaft, and *c* and *d* two beveled wheels mounted loosely on the crank-shaft, and gearing with an intermediate beveled wheel, *e*. The shedding and shuttle-box motions of any well-known kind may be driven either from the shaft *e'* or from the spur-wheel *e'*, fixed to the beveled wheel *c*. Both of these methods are well known. A clutch-box made in two parts, *f f'*, is capable of sliding on the shaft *b*, but the part *f* always rotates with the shaft, the latter having a feather to enter a groove in the part *f* of the clutch. A rod or bar, *g*, provided with forks *g<sup>1</sup>* and *g<sup>2</sup>*, and moved by a hand-lever, *h*, moves the two parts of the clutch-box, pins on the forks, entering grooves in the parts *f f'*. The part of the clutch *f* connected with the shaft has a slot at *x*, to receive a projection, *x<sup>1</sup>*, from wheel or pinion *c*, and also an annular groove, *x<sup>3</sup>*, and a slot, *x<sup>2</sup>*, leading thereto. Toothed wheel *d* has two projections, *d' d<sup>x</sup>*, one from each side. Projection *d<sup>x</sup>* rests within a groove in the clutch *f'*, and projection *d'* is at times engaged with clutch *f* by entering notch *x<sup>2</sup>*, and when a shoulder on *d'* operates within notch *x<sup>2</sup>* the clutch *f* moves wheel *d*; but when the shoulder on *d'* enters the groove *x<sup>3</sup>*, then the part *f* can move without moving *d*. On clutch-box *f'* is a friction-cone, *k<sup>3</sup>*, which enters a conical seat in the face of a pulley, which may be in practical effect the loose pulley, and mounted on shaft *b* at the side of fast pulley *b<sup>x</sup>*, which receives the driving-belt, and which is driven

as usual. A notched plate, *v*, with notches 1 2 3 4, holds the hand-lever *h* in its adjusted position. An arm, *s*, supported by the loom-frame and provided with a notch or shoulder, rests on a friction-roller, *h'*, on lever *h*, and a link, *i'*, connects this lever with a lever, *m*, for controlling the action of the picking mechanism. These parts so far described, through proper well-known connections with shaft *c'* or pinion *c'*, actuate the shuttle-box and shedding mechanism, of well-known construction, and also throw the picking mechanism into and out of action.

It often happens that a loom has to be reversed to find a true shed or correct mistakes, or the picking action stopped. When the parts are in the position shown in Fig. 1, movement of the crank-shaft, by pulley or otherwise, in the direction of the arrow 1, operates all the parts of the loom, including the shuttle-boxes, shedding mechanism, and picking mechanism, forward in the regular way. If it is desired simply to disconnect the picking mechanism and stop its action, the lever *h* is turned to engage notch 2, instead of notch 1, and then the roller *h'* elevates the lever or arm *s* and link *i'*, connected, as shown at Figs. 2 and 3, with arm *i*, which raises the pivoted arm *n*, connected with the picker-operating shaft *n'*, so that the projection *k'* on wheel *k*, for operating the picking mechanism, cannot strike the arm *n* and operate shaft *n'*. In this condition the other mechanisms of the loom run forward in the regular way. If it is desired to reverse the motion of the shedding and shuttle-box mechanisms, or either to repeat the pattern backward to the last pick or true shed, then the lever *h* is moved to engage catch 3, clutch *f* is disengaged from the loose pinion *c'*, the end of projection *d'* is received in notch *x*<sup>2</sup>, which then connects the loose clutch-box *f'* and wheel or pinion *d* with the shaft *b*, and further movement of shaft *b* in the direction of the arrow will turn the shuttle-box and shedding mechanisms, or either, through shaft *c'* or pinion *c'*, backward, the lay operating as usual, the picking motion being suspended, and these parts may be run back as long as desired.

If it is desired to run the shuttle-box and shedding mechanisms backward, and keep the batten stationary, in order to take out a mispick or a broken pick, or find the true shed or correct imperfect weaving, the hand-lever *h* may be moved to notch 4. This action moves the clutch *f* still farther along on the shaft *b*, causing the projection on *d'* to pass within the groove *x*<sup>3</sup> of clutch *f*, which frees the clutch *f* from the clutch *f'* and wheel *d*, and the cam *k*<sup>3</sup> enters the cone-seat in the loose pulley *n*, and by shifting the driving-belt from the fast to the loose pulley *n*, such pulley, acting on the loose clutch *f'*, connected, however, with pinion *d* by the projection *d*<sup>x</sup>, will reverse the movement of the shedding and shuttle-box mechanisms, the picking mechanism yet

remaining suspended or thrown out of action. In the last position, if the driving-belt is kept on the fast pulley *b*<sup>x</sup>, the batten only will be operated.

In Fig. 3 the picking parts of a loom are brought into operation to pick the shuttle either alternately from each end of the batten, or any number of consecutive times from either end of the batten, as the design to be woven may require. For this purpose I employ the shuttle itself to indicate the pick. Whenever any of the shuttles are brought in their boxes in a line with the shuttle-race, they press out a swell, in the usual manner. This swell is made to elevate a lever or partly revolve a rod on its axis. A finger on the rod or lever comes in contact with another lever during a certain part of the oscillation of the batten, which last lever puts into or out of action the picking motion as often as may be required.

The way in which I prefer to carry this part of my invention into effect is illustrated by Fig. 3, which is a side view of a part of a loom. *g g* are the shuttle-boxes on the batten *r*, and *p* is a shuttle on one of them, pressing out a swell, *p'*, and in doing so moving back the arm *o'* and raising another arm, *o*, both on the same axis, so that as the batten beats up, it may come in contact with the stud *m*<sup>2</sup> on the lever *m*. This lever is mounted on an axis, *m*<sup>1</sup>, having on it another arm, *i*, which, in a manner already described in respect to Fig. 2, lowers the arm *n* of the picking-shaft *n'* into the path of the tappet *k'*. When the arm *o* does not act on the stud *m*<sup>2</sup>, a spring acts on the levers, so as to hold the arm *n* clear of the tappet. Similar apparatus may be used on the opposite side of the loom, or the axis of *o* may be carried through the loom, and on the other side carry a second arm, *i*, which, when depressed, lowers the arm *n*, on which it acts, out of the path of the tappet, so as to prevent a pick being made at this side except when the stud *m*<sup>2</sup> escapes the arm *o*.

Looms have had reversing apparatus by which to discover the lost pick, and at the same time had the facility of suspending the action of the picking; but no loom, to my knowledge, and before my invention, had such facilities combined with a means to suspend the movement of the batten.

The principle of my invention may be stated as follows: An apparatus which will engage in combination with a clutch all the mechanism of the loom, so that the loom may make sheds, operate shuttle-boxes, pick shuttles, &c., in regular order, and that when the loom is stopped, or while in motion, another and different movement of the clutch will cause certain gearing to reverse all the movements of the loom, and at the same time disconnect the picking, or, by disengaging the belt from what may be in reality the fast pulley to what may be in practical effect the loose pulley, a second clutch or friction-

clutch shall engage with the loose pulley and disengage the clutch from the crank-shaft, the belt then turning said pulley, reversing all the movements of the loom except the crank-shaft and picking motion, thus enabling the operator to find the pick, &c., while the first-mentioned clutch-box in one position gives movement to the loom in its weaving condition, and when moved laterally disconnects the picking, and imparts a reverse movement to all parts except the picking. A still further lateral movement also disconnects the crank-shaft, and consequently the lathe, and, when followed or preceded by shipping the belt from the fast to a loose pulley, reverses, for the purpose stated, all the motions of the loom, except the lathe, which is then at rest, as is also the picking motion. This affords a more convenient arrangement than any other now used for withdrawing mispicks and discovering the true shed, from which to resume correct weaving, and distinguishes my invention from all things before known.

I have not shown the details of the harness and shuttle-box operating mechanisms, but have shown the source from which to impart movement to such parts, and mechanism for reversing such parts, and also to reverse such parts and allow the batten to remain at rest.

I claim—

1. The combination of a belt-pulley and a clutch, adapted to be disconnected from the crank-shaft, with a shaft in gear with the clutch-box, whereby, through the belt-pulley and shaft, the shedding and shuttle-box mechanisms may be reversed while the lay is at rest.

2. The combination of a clutch-box, belt, pulley, and gearing, by which the shedding mechanism may be reversed, substantially as described, with a clutch-box adapted to disengage the crank-shaft, that the lathe may be at rest.

3. The combination of the hand-lever and connections with the clutch-box  $f f'$ , the belt, pulley, and gearing, adapted to give movement to shedding mechanism, either backward or forward, substantially as set forth.

4. The combination of two pulleys actuated

by power and their connections or gearing, whereby one of the pulleys, practically a fast pulley, is adapted to move the operative parts of the loom in the regular forward order, and the other pulley, through a belt, to operate other parts of the loom, as described, in a reverse order while the lay is at rest.

5. In a loom adapted for fancy weaving, the combination of the belt-pulley, clutches, and gearing, whereby, when the lay and picking motion are at rest, the other parts of the loom may be operated, substantially as described.

6. In a loom provided with a shaft,  $e'$ , or a pinion,  $e'$ , for imparting movement to shedding and shuttle-box-operating mechanisms, a clutch-box adapted to be disconnected from the crank-shaft and combined with gearing, substantially as described, to change the movement of the parts operating the shuttle-box and harness or shedding mechanisms while the crank-shaft and batten operate, substantially as described.

7. In a loom provided with a clutch-box and gearing for operating the parts which operate the shedding or shuttle-box mechanisms, substantially as described, a picking-shaft and a movable arm,  $n$ , adapted to be thrown out from the path of the actuating-tappet, for operating the picking-shaft when the loom is being reversed or operated to find a last pick or true shed, substantially as described.

8. The fast and loose parts  $f f'$  of the clutch-box, forks  $g^1 g^2$ , bar  $g$ , lever  $h$ , and holder or plate  $v$ , for moving the clutch-box and confining the lever in adjusted position, all substantially as described.

9. The combination of the crank-shaft and the clutch, adapted to be disengaged from the crank-shaft, with a belt-pulley and gearing, to impart movement to shedding and shuttle-box mechanisms, substantially as described.

J. L. NORTON.

Witnesses:

EDWD. N. HOBBS,

AND. BRAUMANN,

Both of 2 Pope's Head Alley, Cornhill,  
London, England, Gentlemen.